

STANDARD HOLE PROCESSING EXAMPLES ①

Unless indicated otherwise, the end face of the hole plates is C0.5. The applications illustrated here are just processing examples. In actual application, it is necessary to consider a wide array of conditions and requirements, including pitch precision between holes, perpendicularity of the holes, surface roughness, roundness, plate material, parallelism, whether or not quenching is required, molding machine precision, product production volume, and tool wear. For this reason, please understand that MISUMI cannot accept any responsibility for problems that may arise from use of these examples.

Ejector Pin

Straight Ejector Pin

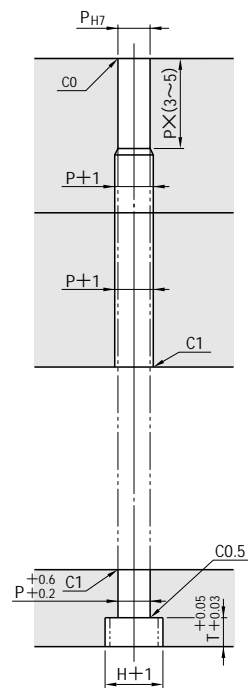

Stepped Ejector Pin

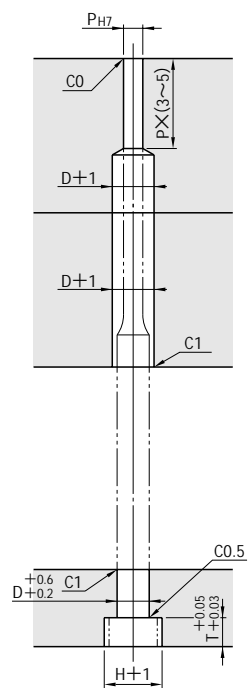

Rectangular Ejector Pin (P · W₀^{-0.01} Tolerance)

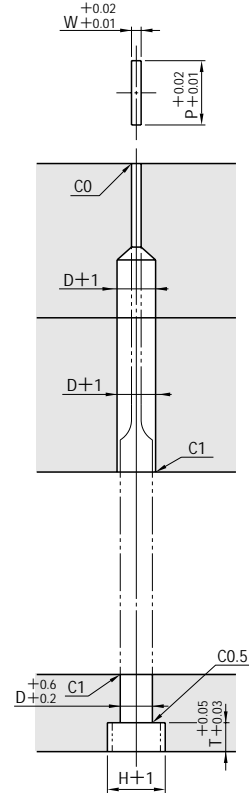

Center Pin

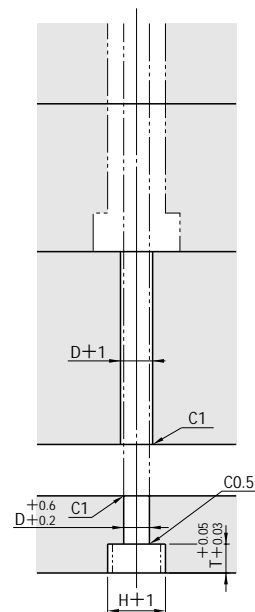

Core Pin

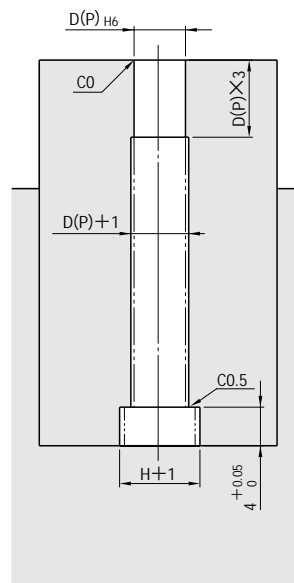

Date Marker Set

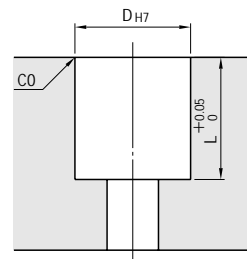

Gas Vents

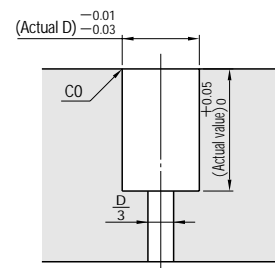

Angular Pin

Angular Pin (AP·APZ)

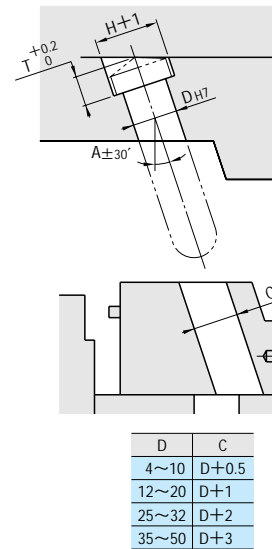

Angular Pin (APS·APZS)

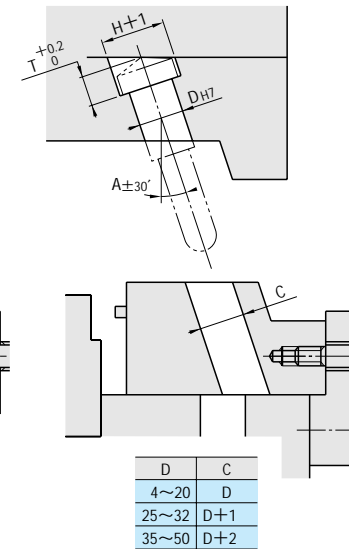

Angular Pin (with tap)

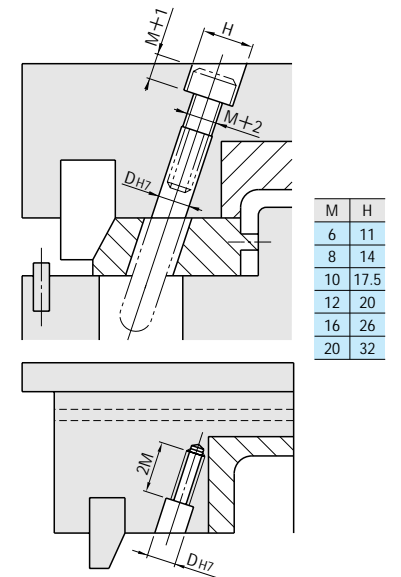

Angular Cam

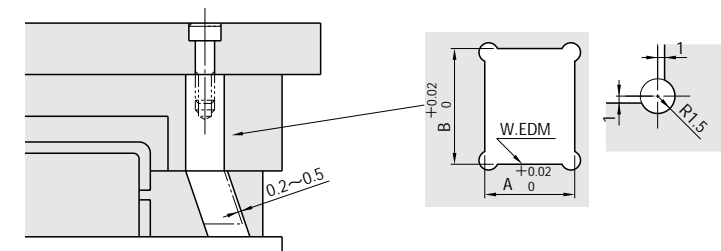

Locking Block

Positioning type

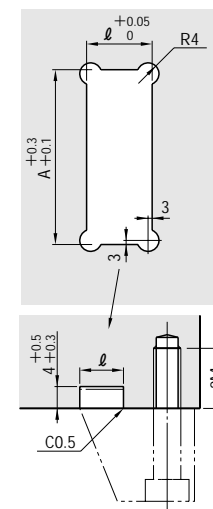

Inlay type

